

LUFTFILTERGERÄT

GT[®] 80L



Bei leichter Luftbelastung durch Öl,
Emulsionen und allgemeine KSS



8000 m³/h

99,95 %

ABSCHIEDERAD

MADE
IN
GERMANY

EXPERTISE IN FILTERS

SINCE 1992



TECHNISCHE DATEN

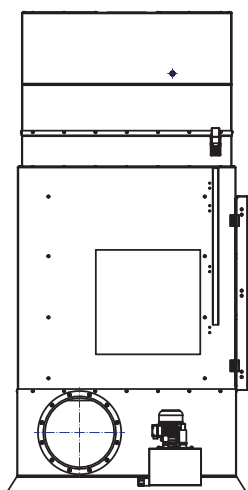
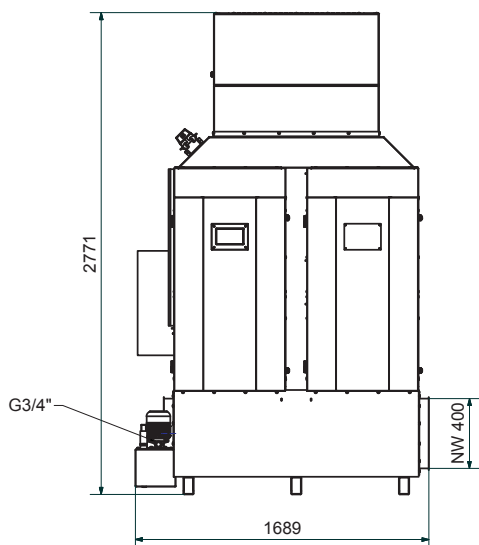
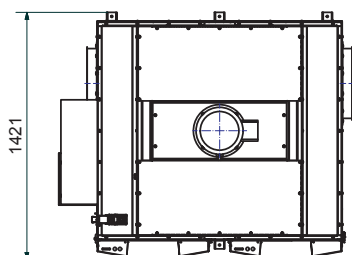

GT[®] 80L

Nenn-Volumenstrom m³/h **8000 m³/h**

Leistung kW max. 7,5

Antriebsart FU optional

Anschluss V | Hz | Phasen 400/460 | 50/60 | 3

L x B x H mm 1421 x 1689 x 2771

Gewicht kg 750

Filterfläche gesamt m²
(min/max)* 124,8/216

1. Filterstufe m² 57,2

2. Filterstufe m² 46,8

3. Filterstufe m² 80,4

4. Filterstufe m² n. v.

5. Filterstufe m² n. v.

Luftanschluss NW mm
(Rohgas/Reingas) 400

ø freier Ölablass“ R 1 ¼

ø Auslass
Ölrückförpumpe“ G ¾

* je nach Anwendungsfall

 integrierte Pumpe

Basisausführung